



PRODUCT SUPPORT MANUAL

Y1-03-0148
Rev. A

Satellite₂[™] 406 and RapidFix[™] 406

Emergency Position
Indicating Radio Beacon
FCC Type Accepted

Product No. 2774 Cat. I
Product No. 2775 Cat. II
Product No. 2776 Cat. I, GPS
Product No. 2777 Cat. II, GPS

Owner _____

Vessel _____

Radio CallSign _____

ACR Electronics, Inc.
5757 Ravenswood Road
Fort Lauderdale, FL 33312
+1(954) 981-3333 • Fax +1 (954) 983-5087
<http://www.acrelectronics.com>
Email: Info@acrelectronics.com

* * * **WARNING** * * *
**THIS TRANSMITTER IS AUTHORIZED FOR USE
ONLY DURING SITUATIONS OF GRAVE
AND IMMINENT DANGER**

**DELIBERATE MISUSE MAY
INCUR A SEVERE PENALTY**

Advice to owners of Emergency Position Indicating Radio Beacons (EPIRBs)

Registration of 406 MHz satellite EPIRB with the EPIRB Registration Section of the *national authority** is mandatory because of the global alerting nature of the system.

The information provided in the Registration Card is used only for rescue purposes.

Fill in the owner registration card immediately upon completion of the sales transaction. Mail the Registration Card immediately.

If the beacon is to enter service immediately, complete the Registration Card and fax the information to the national authority. The original card must still be mailed to the *national authority** for hard-copy reference and filing.

If the current owner is transferring the beacon to a new owner, the current owner is required to inform the *national authority** by letter, facsimile or telephone, of the name and address of the new owner.

The subsequent owner of the beacon is required to provide the *national authority** with the information as shown on the owner Registration Card.

This obligation transfers to all subsequent owners.

*National Authority

The term "national authority" appears throughout this manual. Wherever these words appear, reference is made to the government body responsible for EPIRB registration for the country in which the vessel is registered. The addresses for various national authorities can be found on the Registration Card appropriate for your vessel.

The national authority in the U.S.A. is NOAA. The NOAA registration telephone no. is 1-888-212-7283 (toll free).

Note: In the U.S.A. please use the enclosed FCC FORM 506 to modify your radio station license if necessary. For information on whether you need a radiostation license, call 1-888-CALLFCC (toll free)

SECTION 1 - THE SYSTEM

1.1 GENERAL

- 1.1.1 This manual provides installation, operation and maintenance instructions for the **Satellite₂TM 406** and **RapidFixTM 406** Emergency Position Indicating Radio Beacon, hereinafter referred to as the Beacon. This section describes the characteristics and details of the Beacon System. The FCC authorizes the use of 406 MHz Radio Beacons by any ship that is also equipped with a VHF Ship Station. This will make the 406 MHz Radio Beacon available for use on most U.S. ships and boats. EPIRB carriage requirements are contained in USCG regulations.

1.2 PURPOSE

- 1.2.1 The **Satellite₂TM 406** and **RapidFixTM 406** Beacon provides distress alerting via radio transmission on 406 MHz to satellites of the COSPAS-SARSAT network. The **RapidFixTM 406** can also transmit a distress alert to the GEOSAR network that includes GPS latitude and longitude coordinates that are inputted through an I/R Interface that connects to the data output of a GPS Receiver.
- 1.2.2 The message transmitted by the **Satellite₂TM 406** and **RapidFixTM 406** is unique for each EPIRB, which provides identification of the transmitter through computer access of registration files maintained by the National Oceanic and Atmospheric Administration or other national authority. **It is the user's responsibility to fill out and mail the enclosed registration form to the appropriate agency of the country under which the vessel is registered.** US flagged vessels send the enclosed NOAA/NESDIS form to NOAA in the stamped envelope provided. For vessels registered in other countries, the **Satellite₂TM 406** and **RapidFixTM 406** must be reprogrammed by an ACR authorized programming facility for the registered country. **Remember**, if your EPIRB is **not registered**, SAR Authorities do not know who you are, what type of vessel, your homeport, or where to contact anyone who might know anything about your situation.
- 1.2.3 Once the Satellite₂TM 406 and RapidFixTM 406 signal (406 MHz), relayed through the COSPAS-SARSAT and/or GEOSAR network

alert Search and Rescue (SAR) forces, they can converge on the GPS navigation position (**RapidFix™ 406** only) or the position estimated by the satellite. When a **RapidFix™ 406** with GPS interface is used

SAR authorities can know your precise location immediately and speed up reaction time. The **Satellite2™ 406** and **Rapid-Fix™ 406** on board radio beacon transmitter (121.5 MHz) and high intensity xenon strobe light aid intermediate and short-range location.

- 1.2.4 Product numbers 2774 and 2776 (Category 1 **Satellite₂™ 406** and Category 1 **RapidFix™ 406**) may be deployed and activated automatically by the built-in hydrostatic float free release. Once free from the release bracket, the **Satellite₂™ 406** and **RapidFix™ 406** will automatically turn on if the water sensors are wet.
- 1.2.5 Alternately, the **Satellite₂™ 406** and **RapidFix™ 406** can be manually activated by lifting the thumb switch to a vertical position, sliding it toward the antenna and pushing back down to the opposite side of the EPIRB. Activating the beacon in this manner breaks off the "Activation Indicator Plastic Pin" and allows the switch to properly seat, showing the " ■ " symbol (ON).
- 1.2.6 Self contained long life batteries with a five-year recommended replacement cycle provide power. *See Factory Authorized Service Center for replacement (Section 4.0 – Maintenance).*
- 1.2.7 Self-test is initiated by momentarily lifting the thumb switch to a vertical position and holding it in this position for at least one second. A beep and the simultaneous lighting of the green and red LED's indicate the initiation of the test. The buzzer will beep three times as both the red and green LED's light simultaneously. The green LED will then light, followed by a flash of the strobe, indicating a successful test. During self-test, an actual satellite message is transmitted while certain key performance parameters are measured and recorded. The self-test message is modified to prevent the satellite from forwarding an alert message during self-test.

- 1.2.8 Following self test, the **RapidFix™ 406** (if GPS data has been acquired), will beep and simultaneously light the green and red LED's, to indicate GPS data has been stored in the Beacon. This GPS data would be included in the transmitted message if the Beacon were to be activated. (See Section 3.7)

1.3 SATELLITE DETECTION

- 1.3.1 The **Satellite₂™ 406 and RapidFix™ 406** transmits an encoded phase modulated radio signal to the satellite portion of the COSPAS-SARSAT System. The system was developed and implemented by the COSPAS-SARSAT Partners (Russian Federation, Canada, France and the United States).
- 1.3.2 COSPAS-SARSAT is an international system that uses Russian Federation and United States low altitude, near-polar orbiting satellites that assist in detecting and locating activated 121.5/243 MHz EPIRBs and 406 MHz Satellite EPIRBs. The Russian Federation provides aboard COSMOS navigation spacecraft COSPAS payloads that are inter-operable with the SARSAT System. In addition to weather and environmental sensors, SARSAT payloads, provided by Canada and France, are carried aboard the United States National Oceanic and Atmospheric Administration's (NOAA's) Advanced TIROS environmental satellites. (See Figure 1: Satellite Detection)
- 1.3.3 COSPAS and SARSAT satellites receive distress signals from satellite EPIRBs transmitting on the frequency of 406.025 MHz. The COSPAS-SARSAT 406 MHz satellite EPIRB signal consists of a transmission of non-modulated carrier followed by a digital message format that provides identification data. The 406 MHz system uses spacecraft-borne equipment to measure and store the Doppler-shifted frequency along with the satellite EPIRB digital data message and time of measurement. This information is transmitted in real time to an earth station called the Local User Terminal (LUT), which may be within the view of the satellite, as well as being stored for later transmission to other LUTs. In the real-time mode, the signal detection is limited to a mutual EPIRB-satellite-LUT circular visibility area of about 2500 km radius that moves with the satellite along its track. However, because of the stored-mode

capability at 406 MHz, the need for this mutual EPIRB-satellite-LUT visibility is not essential, and the system is fully functional worldwide.

- 1.3.4 The LUT processes the Doppler-shifted signal and determines the location of the satellite EPIRB; then the LUT relays the position of the distress to a Mission Control Center (MCC) where the distress alert and location information is immediately forwarded to an appropriate maritime Rescue Coordination Center (RCC). The RCC dispatches Search and Rescue (SAR) forces.
- 1.3.5 The COSPAS-SARSAT System includes 36 LEOSAR LUT stations, 6 GEOSAR LUT stations and 19 Mission Control Centers that provide real-time as well as global-mode coverage for the Northern Hemisphere, while the Southern Hemisphere is presently served primarily by the global mode. Additional LUTs and MCCs are planned for installation in the near future both in the northern and southern hemispheres.

The addition of the GEOSAR Satellite system greatly improves the reaction time for a SAR event. This satellite system has no Doppler capabilities at 406 but will relay the distress alert to any of the LUT stations. When there is GPS data included in the distress message this will instantly tell SAR authorities where you are located at. Hence speeding up the reaction time by not having to wait for one of the LEOSAR satellite's to come around.

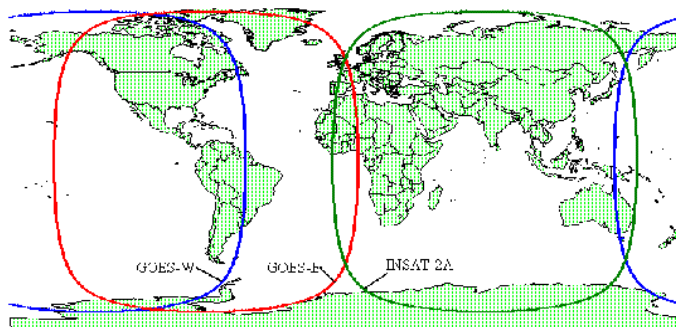

GEOSAR SATELLITE COVERAGE
Figure 1

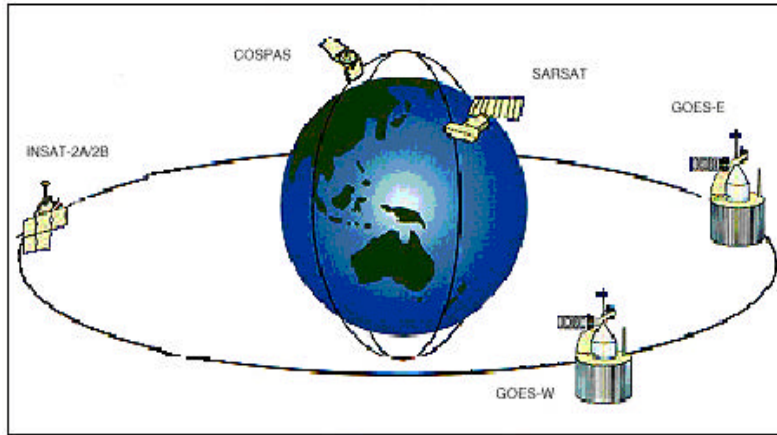

SAR SATELLITE ORBITS
Figure 2

- 1.3.6 Because most of the search and rescue forces presently are not equipped to home on the 406 MHz Satellite EPIRB signal, homing must be accomplished at 121.5 MHz.
- 1.3.7 The **SatelliteTM 406** and **RapidFixTM 406** EPIRB are available in multiple combinations. The following product codes define the options available to meet specific operational requirements:

Prod. No.	Model No.	Cat. I	Cat. II	GPS Interface
2774	RLB-32	X		
2775	RLB-32		X	
2776	RLB-33	X		X
2777	RLB-33		X	X

Note: All models above conform to Class 1 Requirements (operations: -40°C to 55° C storage: -50°C to 70°C)

1.4 AUTHORIZATIONS

- 1.4.1 The **Satellite₂TM 406 and RapidFixTM 406** EPIRB meets the requirements of Federal Communications Commission (FCC) Part 80 (Product No.'s 2774, 2775, 2776, and 2777) and GMDSS (Product No.'s 2774 and 2776)

1.5 CHARACTERISTICS

- 1.5.1 The **Satellite₂TM 406 and RapidFixTM 406** EPIRB is a floatable, battery operated unit. The beacon case, with its external antenna, is waterproof. The semiconductor circuits are mounted within the case assembly that also contains the battery power supply. A "Test/On" switch is installed on top of the beacon, along with a strobe light. The beacon must be stored in its special mount, free of obstructions aboard a vessel for automatic float-off. The unit is self-buoyant and no external floatation devices are required.

1.6 TECHNICAL DATA - **Satellite₂TM 406 and RapidFixTM 406**

1.6.1 Applicable Documents

RTCM	Standard for 406 MHz Satellite EPIRBs
COSPAS-SARSAT	Document C/S T.001 Oct. 98
FCC	Part 80 (Model No.'s RLB-32 and RLB-33) and GMDSS (Product No.'s 2774 & 2776)

1.6.2 Specifications

406 MHz Transmitter

Frequency	406.028 MHz
Frequency Stability	±2 parts per billion/100ms
Output Power	5 watts
Digital Message	
Format	RLB-32: Serialized ¹ RLB-33: Serialized ²
Duration	440 ms (RLB-32) 520 ms (RLB-33)
Rate	400 bps
Encoding	Biphase L
Modulation	±1.1 radians peak

¹ Leaves ACR with Serialized U.S. code but can be reprogrammed at a service center to Maritime or other coded format including nationality of registration.

² Leaves ACR with Serialized U.S. code but can be reprogrammed at a Service center to Maritime MMSI.

121.5 MHz Transmitter

Frequency	121.5 MHz
Frequency Tolerance	±50 ppm
Output Power	25 mW PEP
Modulation	
Type	AM (3K20A3X)
Sweep Range	400 to 1200 Hz
Sweep Rate	3 Hz
Duty Cycle	37.5%

Antenna

Frequency	406.025 & 121.500 MHz
Polarization	Vertical
VSWR	Less than 1.5/1

Xenon Strobe

Light Color	White
Output Power	0.75 effective candela
Flash Rate	20—30 per minute

General/Environmental

Battery Life	
Operating	48 hours minimum
Replacement Interval	5 years
Size	
EPIRB less Antenna	7.20" (18.29 cm)
Antenna	7.39" (18.77 cm)
Material, EPIRB	High impact and UV resistant plastic
Color	Yellow
Weight	1.9 lbs.
Temperature Range	
Operating	Class I -40°C to +55°C
Stowage	Class I -50°C to +70°C

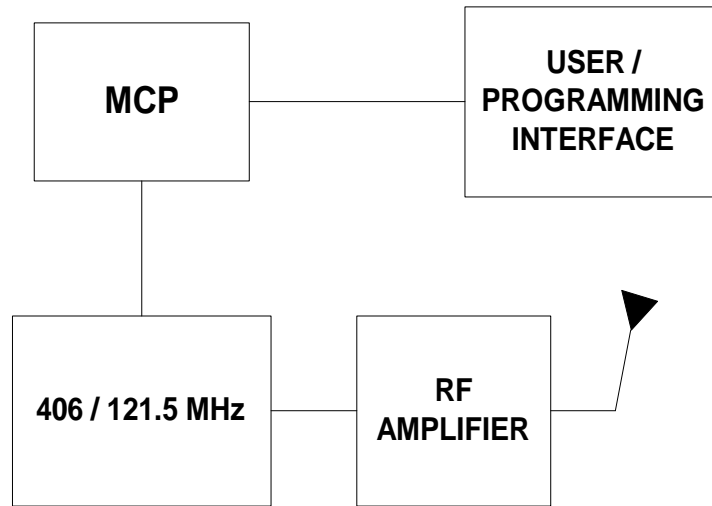

**EPIRB BLOCK DIAGRAM
FIGURE 3**

Manufacturer	Model	Notes	Y2K and EOW Compliant
B&G	Network LCD Plotter / DGPS	*	Yes
B&G	Network LCD Plotter / GPS	*	Yes
B&G	Network GPS and DGPS	*	Yes
B&G	Network GPS	*	Yes
Data Marine	Chartlink D7000 XT	*	Yes
Data Marine	Chartlink D7000 XTC	*	Yes
Data Marine	Chartlink II D8000	*	Yes
Data Marine	Link D3500	*	Yes
Data Marine	Link D3500 LD	*	Yes
Furuno	GP1810F	*	Yes
Furuno	GP1810	*	Yes
Furuno	GP1610C	*	Yes
Furuno	GP1600F	*	Yes
Furuno	GP1600	*	Yes
Furuno	GP30	*	Yes
Furuno	GP35	*	Yes
Garmin	10	*	Yes
Garmin	12	*	Yes
Garmin	20	*	Yes
Garmin	25	*	Yes
Garmin	30	*	Yes
Garmin	31	*	Yes
Garmin	35	*	Yes
Garmin	36	*	Yes
Garmin	38	*	Yes
Garmin	40	*	Yes
Garmin	45	*	Yes
Garmin	48	*	Yes
Garmin	50	*	Yes
Garmin	75	*	Yes
Garmin	85	*	Yes

Manufacturer	Model	Notes	Y2K and EOW Compliant
Garmin	89	*	Yes
Garmin	90	*	Yes
Garmin	92	*	Yes
Garmin	95	*	Yes
Garmin	120	*	Yes
Garmin	126	*	Yes
Garmin	128	*	Yes
Garmin	130	*	Yes
Garmin	135	*	Yes
Garmin	175	*	Yes
Garmin	180	*	Yes
Garmin	185	*	Yes
Garmin	190	*	Yes
Garmin	195	*	Yes
Garmin	210	*	Yes
Garmin	GPSMAP 215	*	Yes
Garmin	220	*	Yes
Garmin	GPSMAP 225	*	Yes
Garmin	GPSMAP 230	*	Yes
Garmin	GPSMAP 235 SOUNDER	*	Yes
Garmin	120XL	*	Yes
Garmin	12XL	*	Yes
Garmin	45XL	*	Yes
Garmin	55AVD	*	Yes
Garmin	95XL	*	Yes
Garmin	GPS II	*	Yes
Garmin	GPS II+	*	Yes
Garmin	GPS III	*	Yes
Lowrance	GlobalMap 12	*	Yes
Lowrance	GlobalMap 1600	*	Yes
Lowrance	GlobalMap Sport	Some older versions of software may not output GGA, contact Manufacturer	Yes
Lowrance	LMS-160	*	Yes
Magellan	GPS 2000 XL	*	Yes

Manufacturer	Model	Notes	Y2K and EOW Compliant
Magellan	GPS 3000	*	Yes
Magellan	GPS 3000 XL	*	Yes
Magellan	GPS 4000	*	Yes
Magellan	GPS 4000XL	*	Yes
Magellan	Meridian XL	*	Yes
Magellan	Trailblazer	*	Yes
Magellan	Trailblazer XL	*	Yes
Magellan	White Meridian	*	Yes
NorthStar	941X	*	Yes
NorthStar	951X	*	Yes
NorthStar	961X	*	Yes
Raytheon	Autohelm ST50 Plus GPS	*	Yes
Raytheon	GPS-11	*	Yes
Raytheon	HSB Chart Plotter	*	Yes
Raytheon	NavCenter 600	*	Unit will display wrong time and date after Y2K. Send unit to manufacturer for upgrade
Raytheon	Raychart 620	*	Unit will display wrong time and date after Y2K. Send unit to manufacturer for upgrade
Raytheon	RC-520	*	Yes
Raytheon	RL-70RC	*	Yes
Si-Tex	DGPS-11	*	Yes
Si-Tex	GPS-1	*	Yes
Si-Tex	GPS-10	*	Yes
Si-Tex	GPS-10A	*	Yes
Si-Tex	GPS-4A	*	Yes
Si-Tex	GPS-5	*	Yes
Si-Tex	GPS-6	*	Yes
Si-Tex	GPS-7	*	Yes
Si-Tex	GPS-77P	*	Yes
Si-Tex	GPS-8	*	Yes

Manufacturer	Model	Notes	Y2K and EOW Compliant
Si-Tex	GPS-88P	*	Yes
Si-Tex	GPS-9	*	Yes
Si-Tex	GPS-99P	*	Yes
Si-Tex	GPS-9D	*	Yes
Si-Tex	HG-7	*	Yes
Si-Tex	SBR-90	*	Yes
Si-Tex	SBR-91	*	Yes
Trimble	4000DSi	*	Firmware must be upgraded to V7.19 to comply
Trimble	4000RSi	*	Users of Firmware V7.15 - V7.18 must upgrade to V7.19. Users of V7.28 must upgrade to V7.29. Users of V7.29 are fully compliant
Trimble	7400MSi	*	Yes
Trimble	MS750	*	Yes
Trimble	Navgraphic XL	*	N/A - No Date Output
Trimble	NavMariner DGPS	*	Yes
Trimble	NavTrac GPS	*	Version 2.09 is compliant. Earlier versions are not being tested
Trimble	NT200	*	Yes
Trimble	NT200D	*	Yes
Trimble	NT300D	*	Yes
Trimble	DSM	*	Yes for versions 1.10 and later
Trimble	NT100	*	Yes

GPS units compatible with ACR Beacons based on vendor information
 (*) indicates that unit complies with ACR requirements

**Known Compatible GPS Receivers
 FIGURE 4**

Mounting Case (Product No's 2774 & 2776 only)

Construction White High Impact and UV resistant plastic
Size 6.5" x 17.1" (16.51 cm x 43.4 cm)

Release System Hydrostatic with manual override

Hydrostatic Release Kits

No. 9367 **Satellite₂TM 406 and RapidFixTM 406**

Replacement Parts

GPS Plug RapidFix Cat 1 9391
GPS Plug RapidFix Cat 2 9390

Optional Mounting Brackets are available for Product No's 2775 and 2777.

Construction White High Impact and UV resistant plastic
Size 6.0" x 7.7" (15.2 cm x 19.5 cm)

SECTION 2 - INSTALLATION (Attach antenna tightly onto unit)

2.1 MOUNTING LOCATION (Product No's 2774, 2776)

2.1.1 The **Satellite₂TM 406 and RapidFixTM 406** float-off mounting bracket should be mounted securely to a *vertical or horizontal surface* (the mount has predrilled holes for attachment to a flat surface) where there are no overhead obstructions. Location aboard a vessel must be chosen to allow the EPIRB to float free of sinking craft and as high as possible especially on small vessels. This will help ensure operation of the hydrostatic release unit in the event the vessel capsizes without sinking.

2.1.2 The location selected must be sufficiently rigid to support the weight of the total installation and at the same time consider vibration, exposure to the elements, exposure to surrounding hazards such as equipment movement, doors being opened, accidental covering, personnel traffic, etc., and yet be readily accessible at all times for the emergency use for which the beacon is intended.

- 2.1.3 Also to be considered in selecting a location for installation is the harmful effect that certain corrosive vapors might have on the beacon. Under no circumstances should a location be selected for installation where the beacon would be jeopardized by any foreign articles being temporarily or permanently positioned during “at sea” or “in port” activities.

CAUTION: Care must be taken to prevent any lanyard, line, or other emergency equipment that may be attached to the beacon from becoming entangled or fouled which could prevent the beacon from being removed in an emergency.

- 2.1.4 The **Satellite₂TM 406 and RapidFixTM 406** float-off mounting bracket should be securely attached to the vessel. The use of #10 stainless steel hardware is recommended.
- 2.1.5 Do not mount the **Satellite₂TM 406 and RapidFixTM 406** in the vicinity (2 meters) of strong magnetic (such as loud speakers) or electric (such as radar or high power radio transmitter) fields.
- 2.1.6 Consideration should be given to mounting the **Satellite₂TM 406 and RapidFixTM 406** in a vertical (antenna upward position). In certain circumstances, such as medical emergencies or disabled vessels, manual activation of the EPIRB for location and homing purposes is sometimes requested. Mounting in this orientation provides the best homing signal.

2.2 VISUAL INSPECTION

- 2.2.1 Visually inspect the area surrounding the mounting bracket installation site for hidden hazards, obstacles, etc., that may have been overlooked during selection. If there is any doubt as to the ready accessibility to the beacon at all times or if any condition may appear to be questionable, make complete and thorough investigation before making final approval of the installation.

2.3 HYDROSTATIC RELEASE DATING INSTRUCTION

- 2.3.1 The label on the hydrostatic release mechanism inside of the bracket and the replacement date label on the outside of the

bracket MUST be dated with the date of expiration at time of installation according to coastal marine authority regulations.

To record the expiration date on the hydrostatic release mechanism, remove the perforated dates of the label to indicate the month and year two years from date of installation. Write the date of expiration with an indelible marker on the label appearing on the outside cover.

SECTION 3 - OPERATION

3.1 GENERAL

- 3.1.1 The **Satellite₂TM 406 and RapidFixTM 406** Beacon Models 2774, and 2776 are designed to be automatically deployed and activated. The **Satellite₂TM 406 and RapidFixTM 406** may also be hand held on the deck of vessels, or floated in water and attached to a raft or life vest with the lanyard provided. The **Satellite₂TM 406 and RapidFixTM 406** are designed to operate best while floating in water. Hand held operation should be avoided when possible. Do not operate inside liferaft or under any similar cover or canopy.
- 3.1.2 The **Satellite₂TM 406 and RapidFixTM 406** Beacon can be deployed and activated manually in any of the available products.
- 3.1.3 Because many users failed to properly place earlier generation beacons in the “ARMED” or “READY” positions when installing them in their brackets, U.S. and International specifications require the elimination of the “OFF” switch position and the inclusion of sensors to automatically activate the beacon under specific conditions.

The **Satellite₂TM 406 and RapidFixTM 406** are equipped with sensors to detect when it is no longer in its bracket (a deployment condition) and other sensors to determine if it's in water.

Two conditions must be satisfied for the **Satellite₂TM 406 and RapidFixTM 406** to automatically activate:

- 1) It must be out of its bracket,

2) It must be in the water,

Note: Either condition by itself will *not* activate the beacon.

3.1.4 The **Satellite₂TM 406 and RapidFixTM 406** are designed to allow the user to perform periodic testing while EPIRB is in the release bracket to assure a functioning beacon.

3.1.5 Place the **Satellite₂TM 406 and RapidFixTM 406** Product No's 2774 and 2756 into the release bracket with the coiled lanyard inward. The beacon should now be firmly held in the release bracket and ready for automatic deployment.

3.2 AUTOMATIC DEPLOYMENT & DEACTIVATION (Product No's 2774 & 2776 only)

3.2.1 Automatic deployment and activation occurs when the vessel sinks and a hydrostatic release device frees the beacon from the bracket allowing it to float to the surface. Built-in sensors detect that the beacon is no longer in its bracket and is in water. This condition will automatically activate the beacon.

Note: Transmissions of the 121.5 MHz and 406 MHz signal will not occur until 50 seconds after activation.

3.3 MANUAL DEPLOYMENT & ACTIVATION

3.3.1 The **Satellite₂TM 406 and RapidFixTM 406** can be manually deployed by removing the retaining pin, removing the cover, then removing the beacon from the bracket. Once removed, the beacon can be activated by being placed in water or by lifting the thumb switch towards the antenna and placing the thumb switch back down on the opposite side of the EPIRB. Activating the beacon in this manner breaks off the Activation Indicator Plastic Pin and exposes the "ON" symbol " ■ " on the thumb switch indicating that the beacon is turned "ON".

Note: Some countries fine vessel owners for causing false alarms. The permanent breakage of the Activation Indicator Plastic Pin is a positive indication of a manual activation.

3.4 MANUAL ACTIVATION WITHOUT DEPLOYMENT

- 3.4.1 The **Satellite₂TM 406** and **RapidFixTM 406** can be activated while still in its bracket by placing the thumb switch in the ON position. Activation by this method overrides all sensors and turns the beacon “ON”.

The caution note above still applies.

3.5 DEACTIVATION

- 3.5.1 The **Satellite₂TM 406** and **RapidFixTM 406** can be deactivated by:

If manually activated:

- 1) Returning the thumb switch to the original OFF position.

If automatically activated:

- 1) Removing the beacon from the water. The beacon normally takes up to 15 seconds to deactivate, or
- 2) Placing the beacon back into the release bracket.

- 3.5.2 If the beacon continues to operate after it has been deactivated, remove the four screws holding the unit together and unplug the battery to disable the unit. Return it to a service center for repair.

3.6 TEST

- 3.6.1 The **Satellite₂TM 406** and **RapidFixTM 406** can be tested in or out of the release bracket. A Self Test is initiated by lifting the thumb switch to a vertical position and holding it in this position for at least one second. The initiation of the test is indicated by a beep and the simultaneous lighting of the green and red LED's.

The sequence of tests is:

1. Check Data Integrity..... Beep and lights up LEDs if passed
..... Stop if failed
2. Check 406 MHz Synthesizer..... Beep and lights up LEDs if passed
..... Stop if failed
3. Check RF Power/Battery..... Beep and lights up LEDs if passed
..... Stop if failed
4. Turn on green LED to indicate Successful Test.
5. Flash Strobe Light to test Strobe.

If all of the above occurs, the test has been successful.

NOTE: The homing beacon at 121.5 MHz is inhibited during self test.

- 3.6.2 It is strongly recommended to test the **SatelliteTM 406 and Rapid-FixTM 406** on a Monthly basis.

3.7 External GPS Interface

3.7.1 Connecting the Rapid FixTM 406 to a GPS via the Optical Interface (IR Transmitter)

Your Rapid FixTM 406 comes with a GPS Optical Interface (transmitter plug with lead wires) and a keyed GPS bezel. The transmitter plug attaches to your Rapid FixTM 406, via the keyed bezel. The GPS Optical Interface lead wires attach to your GPS via the NMEA 0183 connector from your GPS receiver. The black lead wire with white stripes should be connected to the positive transmitter pin. The black wire should be connected to the negative pin.

NOTE: The baud rate output for your GPS receiver NMEA 0183 should be 4800 bps. Consult your GPS manufacturer for correct installation.

3.7.2 Using the GPS Interface

Once a compatible, operating GPS receiver is connected to the **RapidFixTM 406**, the beacon will store data for incorporation into the emergency message, which is transmitted to the satellite. This can provide more accurate positioning data to the Search and Rescue Authority and may lead to faster rescue. Since the last valid GPS position data is always kept in the memory of the **RapidFixTM 406**, the user should take care to make sure that the GPS position data stored is accurate. This can be accomplished by two methods: First,

by always leaving a properly functioning GPS connected to the **RapidFix™ 406** before activation. Second, by connecting a properly functioning GPS with a valid position fix to the **RapidFix™ 406** and allowing sufficient time for the **RapidFix™ 406** to acquire valid position data from the GPS. This will take a nominal 20 minutes if old GPS position data is stored in the **RapidFix™ 406**'s memory. If there is no old GPS position data present, the **RapidFix™ 406** will acquire current data within a minute of being connected to a GPS with a valid position fix. You can force the **RapidFix™ 406** to update its position at any time by initiating the **RapidFix™ 406**'s Self-Test, see 3.7.3 and 3.7.4. If valid GPS position data is not available, it is preferable to reset the **RapidFix™ 406** with the beacon's default message (See Section 3.7.5).

3.7.3 **Testing the GPS Interface**

Connect the Optical Interface Plug to the **Rapid Fix™ 406** bezel and allow sufficient time for the GPS receiver to acquire valid GPS position data (usually less than 1 minute; but it can take up to 30 minutes). Lift the thumb switch to the vertical (Self-Test) position and release. Your **Rapid Fix™ 406** will confirm that it has acquired valid GPS data by emitting a beep along with a flash of the red and green LED's. This will occur approximately 2.5 seconds after the Self-Test.

3.7.4 **Updating GPS Position data**

When the beacon is properly connected to a functioning and compatible GPS receiver, GPS position data is automatically updated about every 20 minutes, while valid GPS position data is present. The operator can force the acquisition of new GPS position data, by executing Self-Test of the beacon. This bypasses the normal, programmed, waiting time of 20 minutes for the automatic update of GPS position data. Once the **RapidFix™ 406** has completed the Self-Test sequence by emitting the beep and flash of red and green LEDs, as described in 3.7.3, the **RapidFix™ 406** will request and acquire new position data from the GPS. This can take a nominal 15 seconds or up to one minute.

NOTE: When the beacon is not activated, GPS position data will be received and stored by the **Rapid Fix™ 406** (**No GPS position data updates will occur while the beacon is activated.**)

3.7.5 Position data set to default:

A new **Rapid Fix™ 406** is programmed with the GPS position data set to “default”. This “default” GPS position data indicates, upon activation, to the satellite system that the beacon has no valid GPS position stored in memory. Once a functioning and compatible GPS receiver is properly connected to the beacon, this “default” data will be replaced by valid GPS position data, as described in the previous sections.

Position data will be reset to default by activating the beacon (turning the beacon ON) and then turning the beacon OFF.

NOTE: The **RapidFix™ 406** should never be turned “ON” except in situations of imminent danger.

ALSO NOTE: The action of turning the beacon ON and then OFF clears any stored GPS position data.

4.0 MAINTENANCE (Check antenna for tightness)

4.1 At least every ninety days, the float free mounting bracket and **Satellite™ 406 and RapidFix™ 406** EPIRB should be inspected for deterioration and/or buildup that may affect the function of the beacon or automatic release.

Also carefully inspect the EPIRB case for any visible cracks. Cracks may admit moisture, which could falsely activate the beacon or otherwise cause a malfunction. Any cracking observed should be immediately referred to ACR for evaluation, (1-800-432-0227 Ext. 112)

4.2 Clean the beacon and the mounting bracket to remove residue buildups. It is recommended that the mounting bracket be waxed with a high quality marine wax.

4.3 The hydrostatic release unit (HRU) must be replaced by the date indicated on the float free mounting bracket. The hydrostatic release can be replaced by removing the Beacon from the bracket, then sliding the hydrostatic release assembly out of the keyed opening on

the spring and mounting bracket. Insert the new hydrostatic release assembly, in place by engaging it to the opening of the ejection spring and case. When servicing the HRU, ACR strongly recommends replacing the entire hydrostatic assembly, including hydrostatic release, release rod and all hardware (P/N 9367). Always use original ACR replacement parts. Use of unauthorized replacement parts may void your warranty. Place beacon into the mounting bracket, and replace cover, securing in place with hitch pin going through the hydrostatic release rod.

- 4.4 The battery (P/N 1096) must be replaced by the date indicated on the beacon. At each inspection, check the time remaining until replacement is required.

NOTE: There are no user serviceable items inside the EPIRB. DO NOT OPEN THE EPIRB UNLESS TO DISABLE IN CASE OF FAULTY ACTIVATION.

Refer all long life battery replacement and other internal EPIRB service to a factory authorized service center.

For the nearest location of a factory authorized service center, call 1-800-432-0227 Ext. 112 (toll free).

- 4.5 The **Satellite2™ 406 and RapidFix™ 406** contain lithium batteries which are not subject to the requirements of the DOT Subchapter C, Hazardous Materials Regulations, because they meet the United Nations Classification of LiS02 Batteries for Shipment of "Non – Dangerous".

5.0 REGISTRATION

- 5.1 It is imperative that this EPIRB be registered with NOAA (National Oceanic and Atmospheric Administration) in the USA or with your own national authority.
The EPIRB has been programmed with a unique identification number or code which is broadcast on 406 MHz. Registration provides the Search and Rescue people with important information which will speed up the rescue operation and minimize false alarms.
- 5.2 To register this EPIRB with NOAA (USA registration only), simply

fill out and mail the provided form in the enclosed pre-addressed envelope to NOAA or fax the completed form to NOAA at (301) 457-5406.

- 5.3 NOAA will supply a Beacon Registration decal which is to be affixed to the **Satellite₂TM 406 and RapidFixTM 406**. The recommended mounting location is on the front of bottom case above the instruction label. (See *Figure 2*)

6.0 FALSE ALARMS

- 6.1 Should there be, for any reason, an inadvertent activation or false alarm, it must be reported to the nearest search and rescue authorities. The information that should be reported includes the satellite EPIRB Unique Identifier Number (UIN); date, time, duration, and cause of activation; and the location at the time of activation.

- 6.2 Contact the following to report false alarms (US):

Atlantic Ocean/Gulf of Mexico—
USCG Atlantic Area Command Center
Tel: (212) 668-7055

Pacific Ocean Area—
USCG Pacific Area Command Center
Tel: (510) 437-3700

From any location—
USCG HQ Command Center
Tel: (800) 323-7233

***** WARNING *****
THIS TRANSMITTER IS AUTHORIZED FOR USE
ONLY DURING SITUATIONS OF GRAVE
AND IMMINENT DANGER

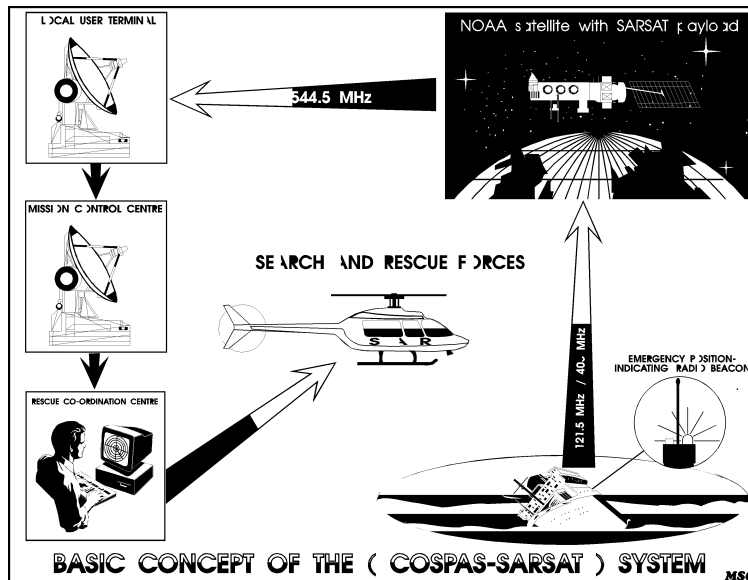

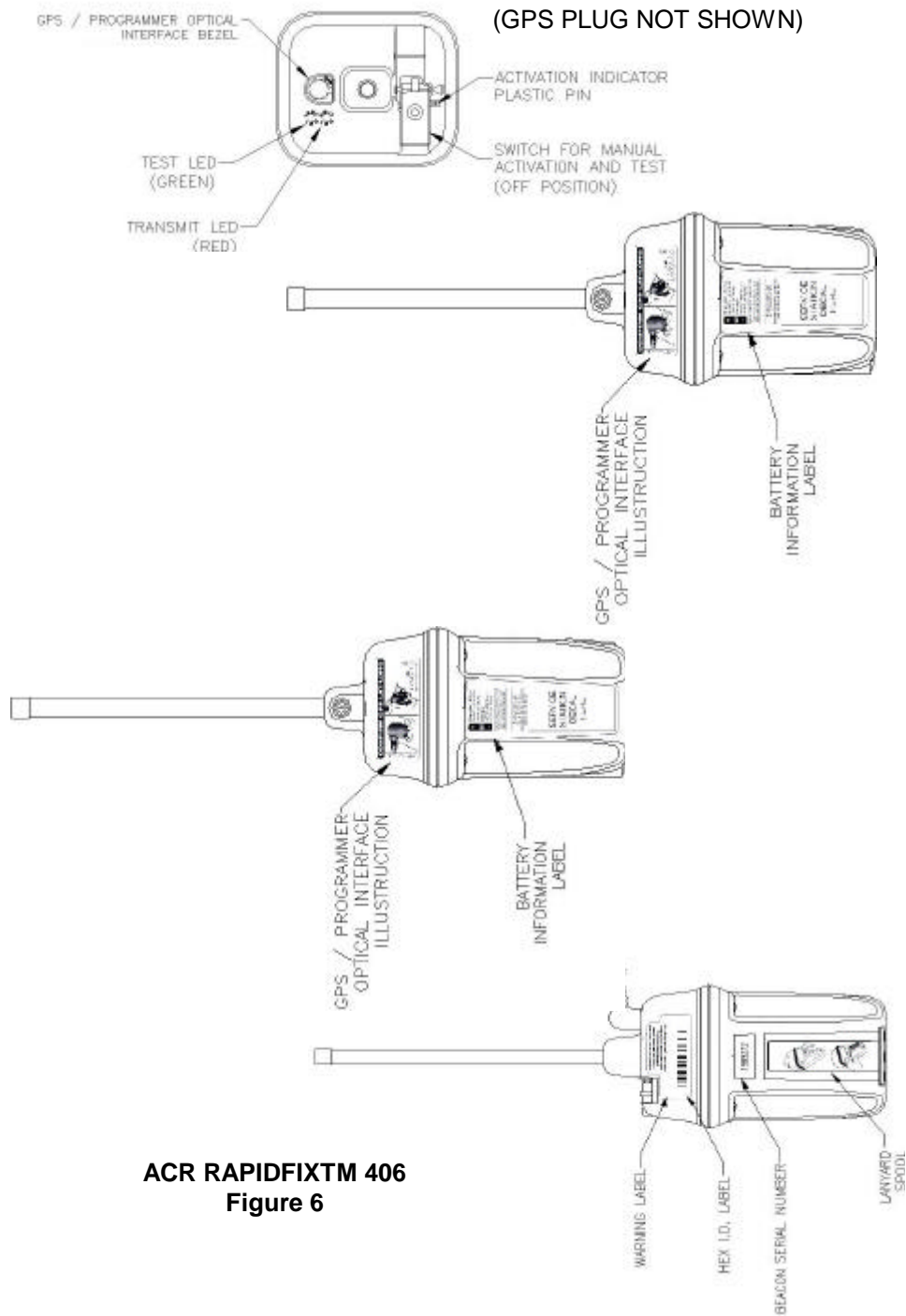

ACR RAPIDFIX™ 406
Figure 6

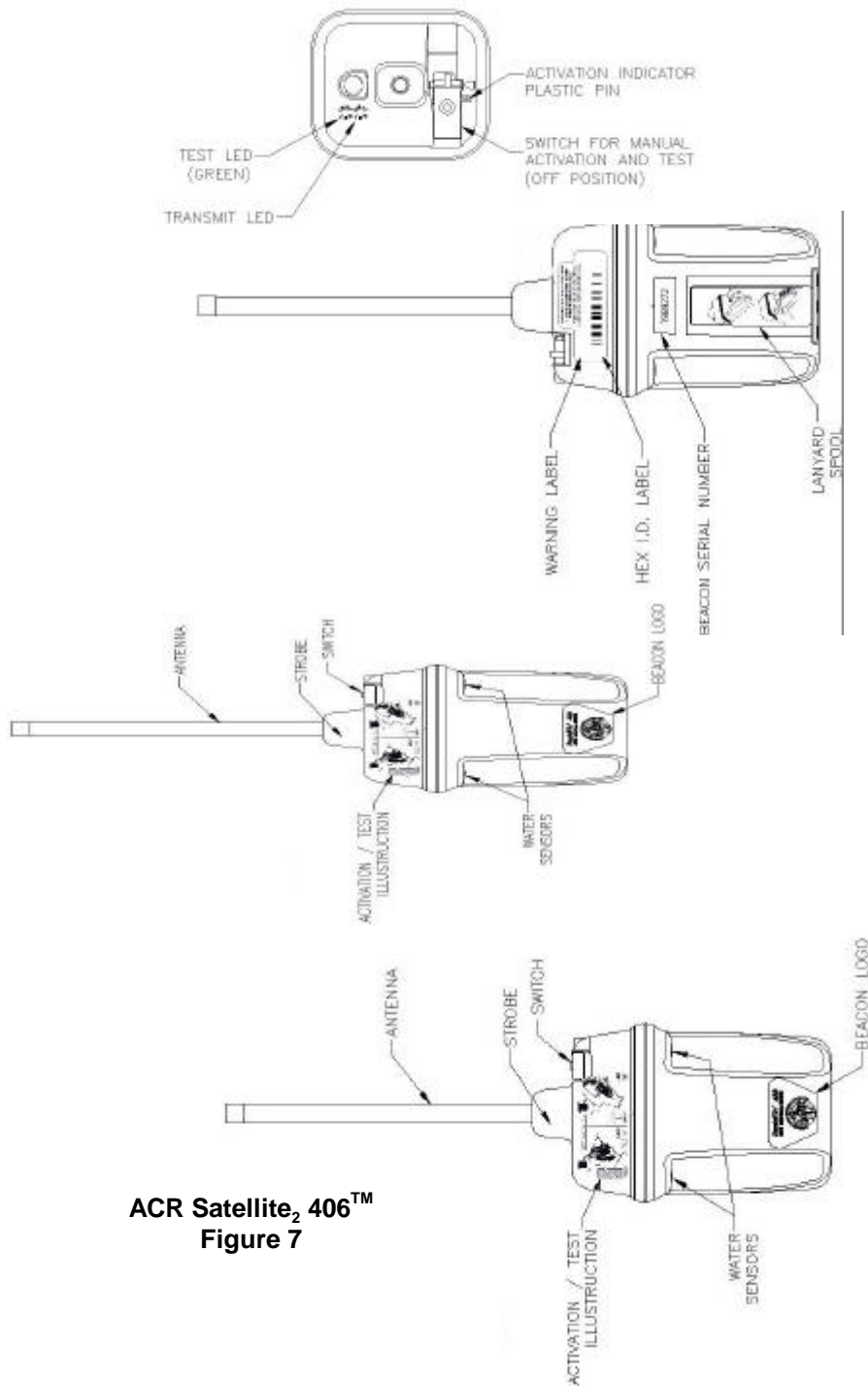

ACR Satellite₂ 406™
Figure 7

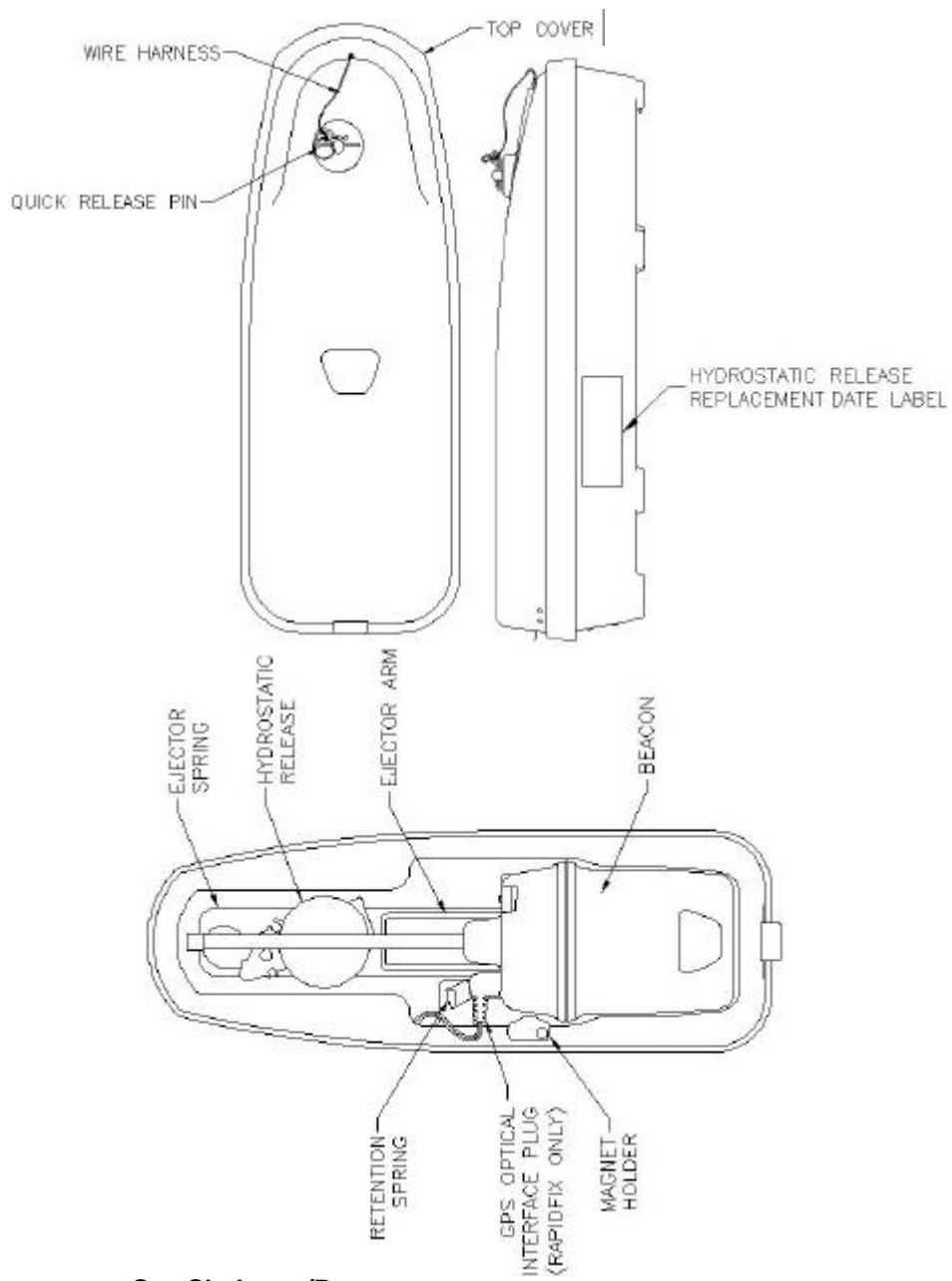

Sea Shelter w/Beacon
Figure 8

